

PART NUMBER

**SSR-143-40-2**



SCAN HERE: To watch a video of this installation



**BEFORE YOU BEGIN**

**PRIMARY APPLICATIONS**

- > Ford F-150 4 X 2  
(2015 - 2020)
- > Ford F-150 4 X 4  
(2015 - 2020)

\*Will not work on Raptor models

**PARTS LIST**

Item	Part #	Description	QTY
A	511419	SumoSprings Blue -40	2
B	512163	Upper Mounting Bracket A (Driver Side)	1
	512164	Upper Mounting Bracket A (Passenger Side)	1
C	512165	Upper Mounting Bracket B	2
D	512166	Lower Mounting Bracket (Passenger Side)	1
	512167	Lower Mounting Bracket (Driver Side)	1
E	512168	3/8" Tag Nut	4
F	112183	3/8" U-Bolt	4
G	512302	3/8" Locking Flange Nut	16
H	512278	3/8 x 1 1/2" Flange Bolt	12
I	512207	3/8 x 3/4" Flange Bolt	6
J	512248	3/8" Fender Washer	4

**TOOLS REQUIRED**

- > Floor Jack
- > Jack Stands
- > Wheel Chocks
- > Ratchet and Sockets
- > Torque Wrench

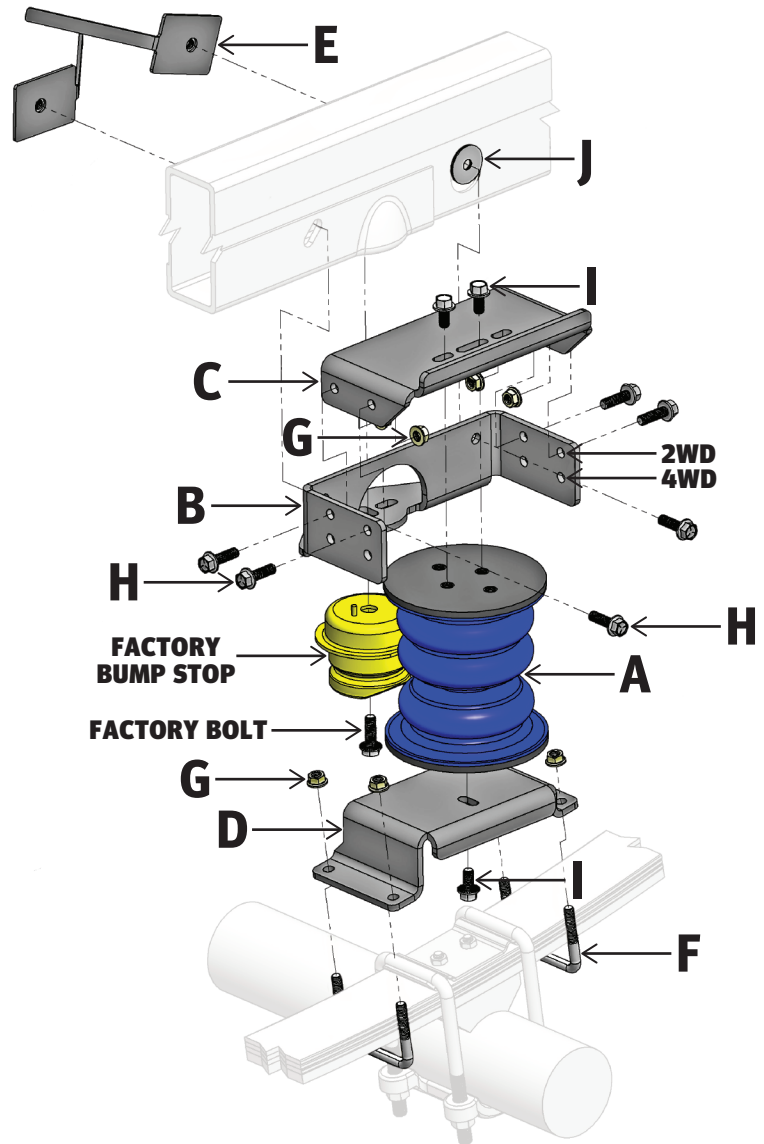

**DRIVER SIDE (PASSENGER SIDE SIMILAR)**

**Part Number: SSR-143-40-2**

**Product Line: SUMOSPRINGS REAR**

**Page 1**

Questions or Concerns?

Scan here:



or visit:  
superspringsinternational.com

**SAFETY NOTICE:** We recommend installation be done by a professional or persons with sound mechanical knowledge.

**WARNING:** These instructions are a general guide for installation. SuperSprings International (SSI) assumes no liability for the actual installation process. Consumers and installers should apply common automotive safety practices when raising and working on any vehicle. **Do not put yourself in a position where, if the vehicle were to move unexpectedly, you may be injured.** SSI's products are designed to improve vehicle ride quality. Do not load any vehicle beyond the manufacturer's specifications.

Never exceed the manufacturer's Gross Vehicle Rating (GVWR) located on your vehicles identification tag.

**BEFORE INSTALLATION:** Ensure the vehicle is on a hard level surface, the parking brake is ON, with the ignition OFF, and place chocks in front of and behind the tires to prevent the vehicle from moving.

**DURING AND/OR AFTER INSTALLATION:** Ensure emergency brake cables are not touching the SSI products. Secure any cables out of the way with zip ties or by re-routing. Ensure all A/C lines, brake cables, and frame are clear of contact or interference.

PART NUMBER

## SSR-143-40-2



### INSTALLATION

1. Park the vehicle on a hard, level surface and engage the emergency brake. Place chocks in front and behind wheels to prevent rolling. Observe all safety precautions and wear safety glasses.
2. Raise the rear of the vehicle allowing the axle to hang free and rest the frame on the safety jack stands rated for the weight of the vehicle. Removal of the rear wheels is optional.
3. Starting on the driver side, remove the factory bump stops from the underside of the frame.
4. Take two of the 3/8" Tag Nuts [ITEM E] and bend the tangs up at about a 45 degree angle. Place them through the oval hole on the inside of the frame rail.
5. Attach the Drivers Side Upper Mounting Bracket A [ITEM B] to the bottom of the frame rail using the factory bump stop and bolt, but leave it loose for now.
6. Place two of the 3/8" Fender Washers [ITEM J] behind the rear hole of the upper mounting bracket.
7. Insert one 3/8 x 1 1/2" Flange Bolt [ITEM H] through the rear hole of the bracket, the 3/8" Fender Washers [ITEM J], and the large hole in the frame. Thread the bolt into the 3/8" Tag Nuts [ITEM E] and fasten until finger-tight.
8. Insert one 3/8 x 1 1/2" Flange Bolt [ITEM H] through the front hole of the bracket and through the hole in the frame. Thread the bolt into the 3/8" Tag Nuts [ITEM E] and fasten until finger-tight.
9. Torque the two mounting bolts and the bump stop bolt to 25 ft. lbs.
10. Fasten the Upper Mounting Bracket B [ITEM C] to the top half of the SumoSpring [ITEM A] using two 3/8 x 3/4" Flange Bolts [ITEM I] through the forward two slots in the bracket and fasten until finger-tight.

11. Attach the Upper Mounting Bracket B [ITEM C] to the Upper Mounting Bracket A [ITEM B] using four 3/8 x 1 1/2" Flange Bolts [ITEM H] and 3/8" Locking Flange Nuts [ITEM G]. Use a torque wrench to tighten the bolts to 25 ft. lbs.

**NOTE:** 2WD trucks use the upper set of holes and 4WD trucks use the lower set of holes.

12. Attach the Lower Mounting Bracket [ITEM D] to the bottom half of the SumoSpring [ITEM A] with one 3/8 x 3/4" Flange Bolts [ITEM I] and fasten until finger-tight.
13. Place the Lower Mounting Bracket [ITEM D] on top of the factory leaf spring so that it straddles the factory top plate. Attach the bracket to the leaf pack using two 3/8" U-Bolts [ITEM F] and four 3/8" Locking flange nuts [ITEM G] and fasten them loosely.
14. Repeat steps 3 through 13 on the passenger side.
15. Once the installation on both sides is at this point, use a jack to raise the axle so the upper and lower halves of the SumoSPrings are almost touching.
16. Using the adjustment slots, align the two halves of the SumoSPrings so they sit vertically aligned.
17. With the driver and passenger sides aligned, tighten the u-bolt nuts securely without tightening to the point of bending the bracket. Torque the rest of the hardware to 25 ft. lbs.
18. Raise the vehicle and remove the safety jack stands.
19. Carefully lower vehicle to the hard surface and remove the chocks from the wheels.
20. Register the warranty for your SuperSprings International part. A warranty card can be found in the box your part came in.

Part Number: SSR-143-40-2

Product Line: SUMOSPRINGS REAR

Page 2

Questions or Concerns?

Scan here:



or visit:  
[superspringsinternational.com](http://superspringsinternational.com)

**SAFETY NOTICE:** We recommend installation be done by a professional or persons with sound mechanical knowledge.

**WARNING:** These instructions are a general guide for installation. SuperSprings International (SSI) assumes no liability for the actual installation process. Consumers and installers should apply common automotive safety practices when raising and working on any vehicle. **Do not put yourself in a position where, if the vehicle were to move unexpectedly, you may be injured.** SSI's products are designed to improve vehicle ride quality. Do not load any vehicle beyond the manufacturer's specifications.

**Never exceed the manufacturer's Gross Vehicle Rating (GVWR) located on your vehicles identification tag.**

**BEFORE INSTALLATION:** Ensure the vehicle is on a hard level surface, the parking brake is ON, with the ignition OFF, and place chocks in front of and behind the tires to prevent the vehicle from moving.

**DURING AND/OR AFTER INSTALLATION:** Ensure emergency brake cables are not touching the SSI products. Secure any cables out of the way with zip ties or by re-routing. Ensure all A/C lines, brake cables, and frame are clear of contact or interference.

REV. 2.01 | SEP 2023